



# CITY OF AMES

## DRIVEWAY / CURB CUT APPLICATION

Return to:  
Public Works Department  
City Hall, 515 Clark Ave  
Ames, IA 50010-0811  
FAX: (515) 239-5404

Property Address: \_\_\_\_\_  
 Contractor: \_\_\_\_\_  
 Address: \_\_\_\_\_  
 Phone: \_\_\_\_\_ Cell: \_\_\_\_\_

NUMBER: \_\_\_\_\_  
 DATE: \_\_\_\_\_

**Fee = \$50.00**

**NOTE:** If you have questions regarding driveway construction, please call 239-5277.

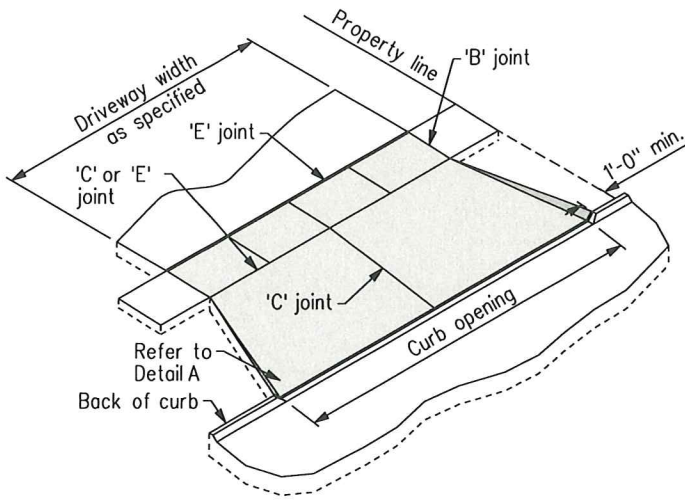

TYPE A WITH FLARES

- ① Pavement thickness.  
Residential: 6 inches minimum.
- ② Sidewalk thickness through driveway to match thickness of driveway.

NOTE: See SUDAS figure 7030.101 for more detail

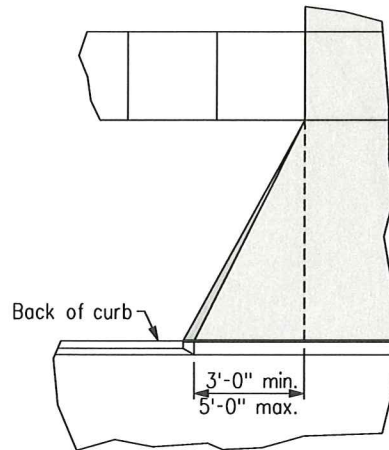

DETAIL A

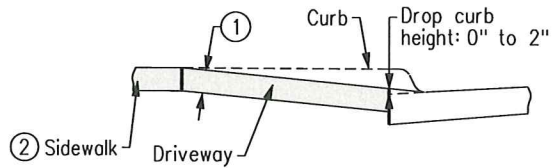

TYPICAL SECTION

**Note:** Driveway approach material **MUST** be concrete.

**Please fill out the following dimensions:**

**Note:** All driveways must lead to side yard or attached garage. One driveway access permitted for properties with frontage less than 150 ft.

\_\_\_\_\_ Driveway Width  
(Minimum = 12 ft / Maximum = 30 ft)

\_\_\_\_\_ Width at Curb  
(Min = 3 ft flares / Max = 5 ft flares)

Is there an intake, fire hydrant, manhole, or other utility located within five feet (5') of the proposed location? (Check One)

**YES**      **NO**

RESTRICTIONS: \_\_\_\_\_  
 \_\_\_\_\_

\_\_\_\_\_  
 Contractor or Owner Signature

\_\_\_\_\_  
 Approved by Traffic Engineer

Copy to: Street Supervisor, Public Works file, Applicant

Billed by Inspections: YES \_\_\_\_\_ NO \_\_\_\_\_

\_\_\_\_\_  
 Expiration Date